

Use and movement areas

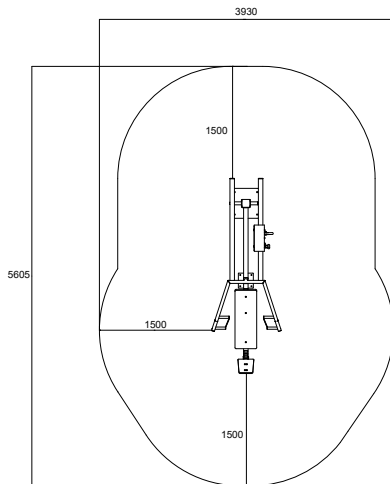

Target muscles

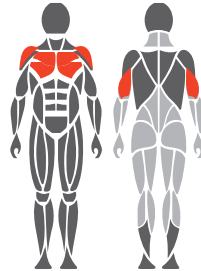

Foundation



1. For example artificial turf or moldable safety platform max. 20 mm
2. Concrete min. 120 mm below equipments
3. Ground frost insulation, thickness based on the ground

Concrete casting and positioning

- Length 2500 mm
Width 1000 mm
Thickness 120-150 mm
- Ground frost insulation
 - Rebaring
 - Adequate drying time must be ensured

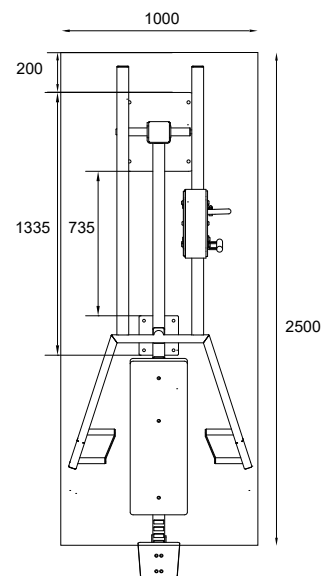

Product specification

Length	2610 mm
Width	930 mm
Height	1430 mm
Equipment weight	170,1 kg (1 x weight unit) 229,3 kg (2 x weight unit)
User height	+ 140 cm
Age	+ 14
Safety area	17,6 m ²
Base	surface mounting to concrete
Standard	EN16630
Country of manufacture	Finland
Metal parts	steel
Tube strengths	3-6 mm
Coating solution	Zink and powder coating

Details

- Adjustable loading
- 2 grip widths/starting heights
- Height adjustable seat
- Maintenance-free polymer bearings
- 15-55 kg (1 x weight unit)
- 10-85 kg (2 x weight units)
- The product comes in RAL Classic colour 5012 (blue) as standard. RAL Classic colours 1017 (yellow), 3020 (red), 6018 (green) and 7036 (grey) are available at an additional cost.

Important

Installation depth for all Omnigym® units: top surface of the concrete base on the ground level or max. -20 mm allowance for the surface material to be used. (See foundation figure)

